

NyQvist Designs

J.Jill

UNISA

andré assous

DANIEL HECHTER
PARIS

Keds



Hush Puppies'

ROCKPORT' 

KHOMBU



RAMPAGE.

ESPRIT

nicole.



Rebels

gomax®

envy



STEGMANN



NyQvist Designs

Services

LINE-BUILDING, SHOE DESIGN AND DEVELOPMENT :

- Market research, customer analysis and trend presentations
- Design for specific categories, consumers or customers i.e. retailers, brands or on-line sales
- CAD drawings, blueprints, complete tech packages
- Materials, color development and specifications for shoes
- Development work on lasts, bottoms and uppers corrections
- Follow sample development through concept to finished shoes
- Presentations to customers, sales or inhouse team

Sandals



STEGMANN



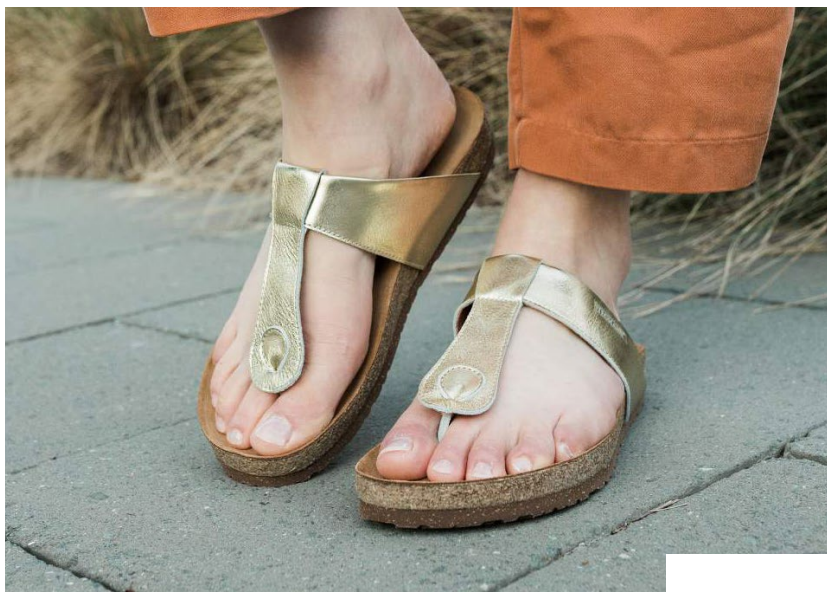

STEGMANN



الزرير

THE CATALOG



Ukies



Ukies



KALSØ

ALL AROUND SANDAL #3 BUCKLE THONG
-MINIMAL STITCHING
-COLOR BLOCK SKU

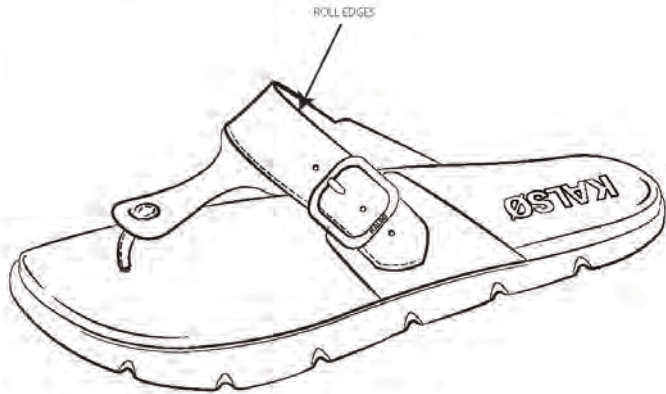

earth

earth



KALSØ

ALL AROUND SANDAL #6-VELCRO STRAP POST-QUARTER SANDAL OR THONG VERSION
-MULTI-COLOR SKU

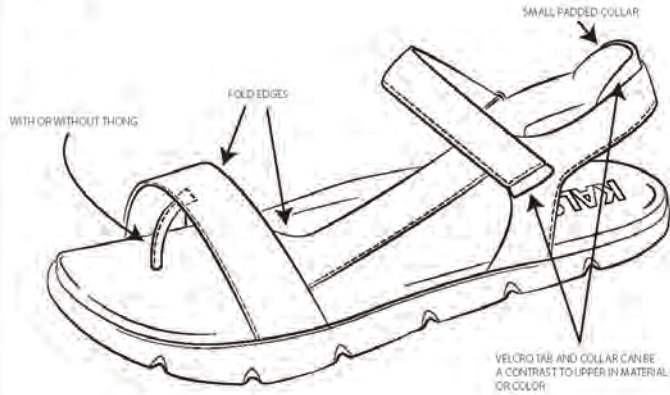

earth



Private Label

FLAT SANDAL #6
CONSTRUCTION AS ACAPULCO



BEADED UPPER.

FLAT SANDAL #2-
CONSTRUCTION AS ACAPULCO

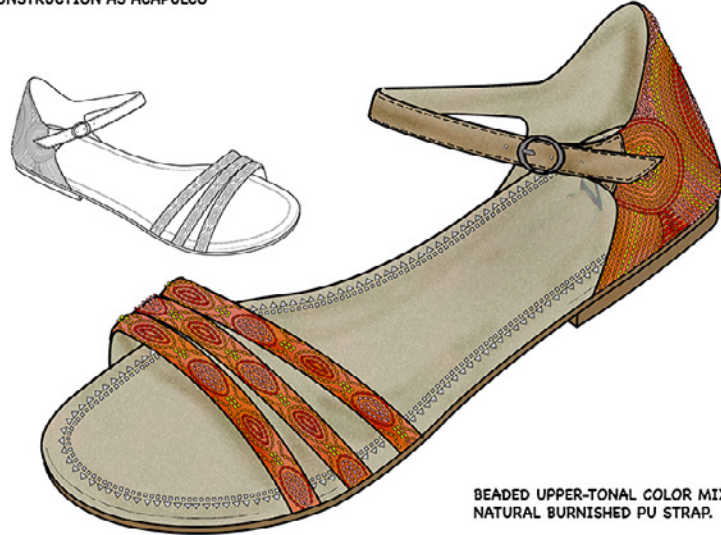

BEADED UPPER-TONAL COLOR MIX
NATURAL BURNISHED PU STRAP.

FLAT SANDAL #9
CONSTRUCTION AS ACAPULCO



SORBET COLORS WITH STONE ORNAMENT.
SOFT METALLICS OR PEARLIZED PU.

LAVISH WEDGE #1
LASER CUT WITH HEAT EMBROSS ON SUEDE SOCK

COMBINE VEG LEATHER TO LINING
LASER CUT THROUGH
STITCH CAN BE NATURAL OR SELF

BUCKLE ON ELASTIC

STOP LASER CUT PATTERN
ABOVE LAST LINE TO ALLOW
FOR GORE.

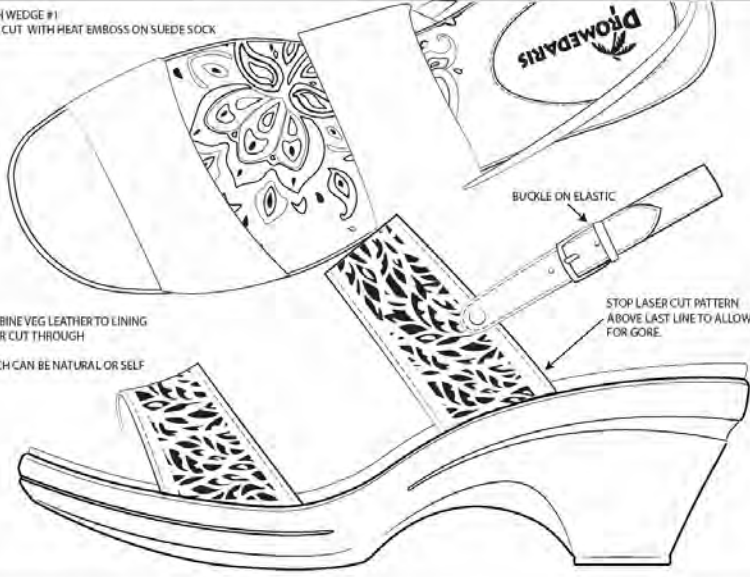

LAVISH WEDGE #4--REVISED
MIXED MEDIA ASYMMETRIC SANDAL
A-ELASTIC
B-LEATHER, METALLIC OR
PONY SKU CAN HAVE
RAW EDGE

BUCKLE ON ELASTIC
BACK GORE LEAVING SMALL
STITCH TOP TO TOP

BUCKLE ON ELASTIC

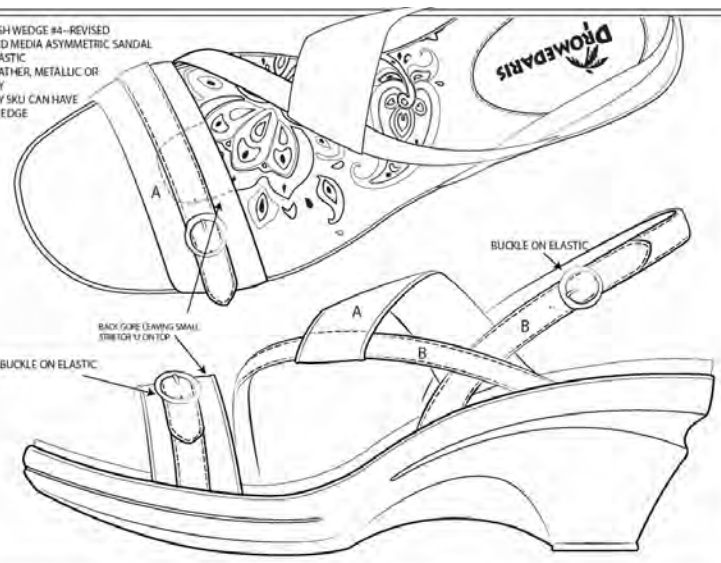

LAVISH WEDGE #3--REVISED
INCLUDE MULTI AND METALLIC SKUs

ELASTIC GHILLET
FIRST STRAP OR TWO
CAN BE NONFUNCTIONAL

BUCKLE ON GORE

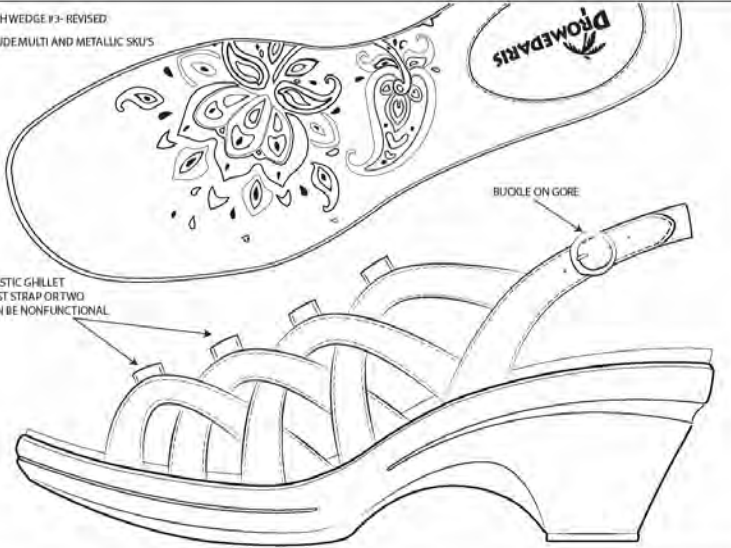

LAVISH WEDGE #12--
LASER CUT VAMP WITH HEAT EMBROSS ON SUEDE SOCK
-SLIDE

ELASTIC TRIANGLE AT LAST LINE
STOP LASER OR STITCH LEATHER
PIECE TO SECURE ELASTIC

OPTION 1

OPTION 2

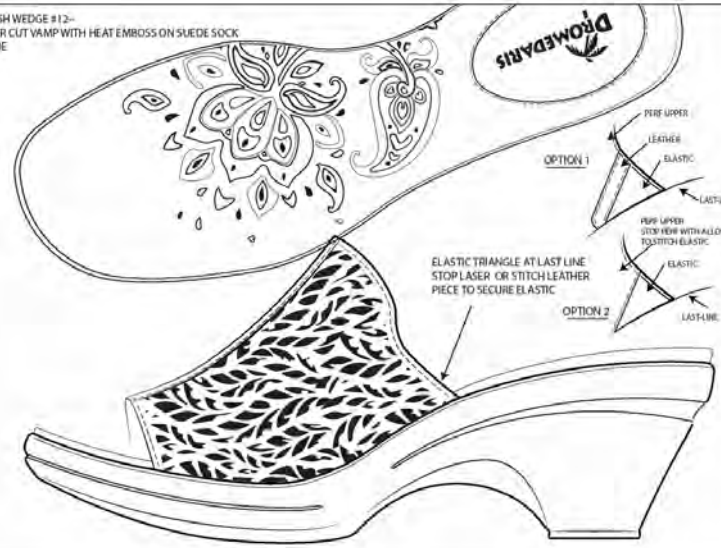
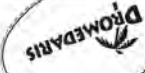

6

UKIES is utilizing some new rope tricks by wrapping the heel of an ankle-strap sandal espadrille style



NORDSTROM



Ukies

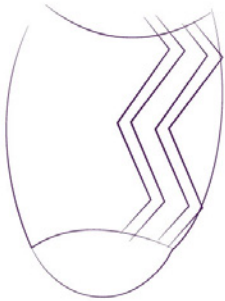

NEW STELLA ROUNDED STACKED HEEL.
HEEL CAN BE COLORED OR WRAPPED IN JUTE

SLIDE UPPER WITH ASYMMETRIC CHEVRON DETAIL
COLOR OR MATERIAL MIX



NEW STELLA ROUNDED STACKED HEEL.
HEEL CAN BE COLORED OR WRAPPED IN JUTE

T-STRAP UPPER
COLOR AND MATERIAL MIX



Lifestyle



STEGMANN





PLEASE SAMPLE ON CLASSIC STEGMANN AND NEW STEGMANN BOTTOM

SKIMMER OR SLIP-ON- FELT AND LEATHER UPPER



P 6

FELT COLLAR

-ALLOVER FELT **NEW BOTTOM**

- ALLOVER LEATHER WITH FELT COLLAR AND CONTRAST STITCH **CLASSIC BOTTOM**

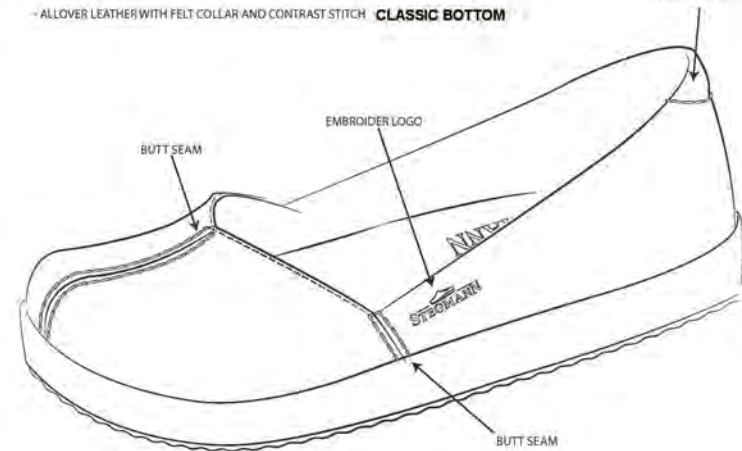

**STEGMANN**



Samuel Hubbard

Samuel HUBBARD
Shoemakers since 1930

WOMEN'S CLASSIC LOW- UPPER 1 LACE/ OXFORD
SPREAD COLORS
NOVELTY SKU OPPORTUNITY

LEATHER WELT EXTENSION

ROLL TOP-LINE

WELT DETAIL

-LEATHER WELT EXTENDS UP AS AN "L" TO CONCEAL LAST VOLUME

● Women's Collection

Samuel HUBBARD
Shoemakers since 1930

WOMEN'S CLASSIC LOW- UPPER 1 LACE/ OXFORD
SPREAD COLORS
NOVELTY SKU OPPORTUNITY

LEATHER WELT EXTENSION

ROLL TOP-LINE

WELT DETAIL

-LEATHER WELT EXTENDS UP AS AN "L" TO CONCEAL LAST VOLUME

● Women's Collection

Samuel HUBBARD
Shoemakers since 1930

WOMEN'S CLASSIC LOW- UPPER 1 LACE/ OXFORD
SPREAD COLORS
NOVELTY SKU OPPORTUNITY

LEATHER WELT EXTENSION

ROLL TOP-LINE

WELT DETAIL

-LEATHER WELT EXTENDS UP AS AN "L" TO CONCEAL LAST VOLUME

● Women's Collection

Samuel HUBBARDTM

Shoemakers since 1930

OPEN SHANK MARY JANE

IF IT IS WELTED YOU COULD HAVE A REMOVABLE SOCK/INSOLE
WRAP AND PAD STITCH SOCK FOR FINISHED SHANK

OR 'STITCH OUT' SHANK AREA TO INSOLE BOARD AS UPPER
-THIS WOULD BE A NON REMOVABLE SOCK

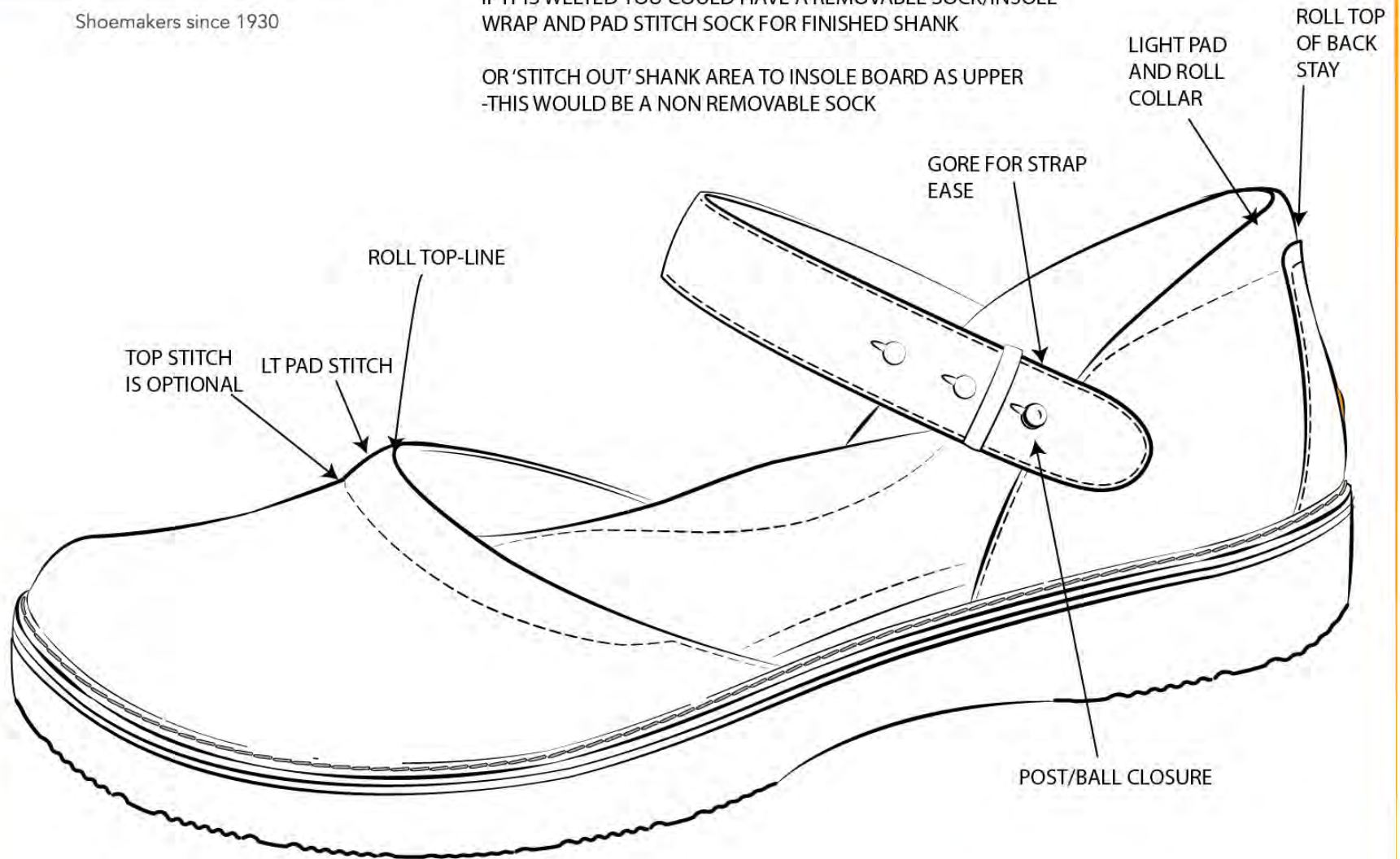

Ukies



Cutout clog/mule with binding
Bottom as Andrea.

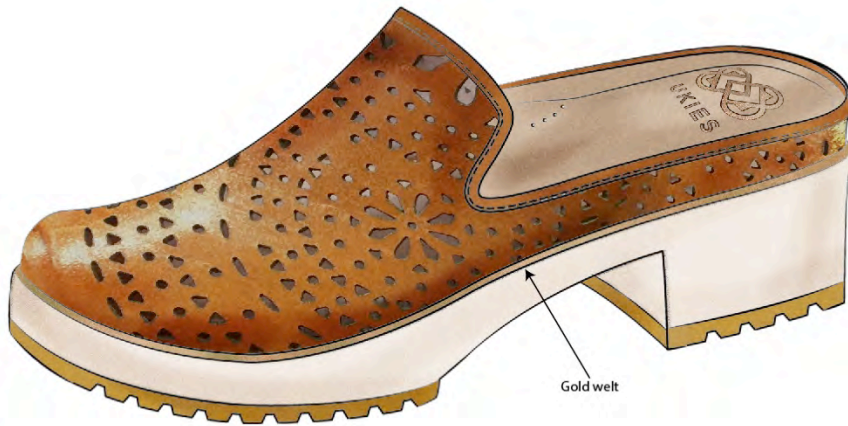

Slip-On with wing tip styling and tassel detail.
Bottom as Andrea.

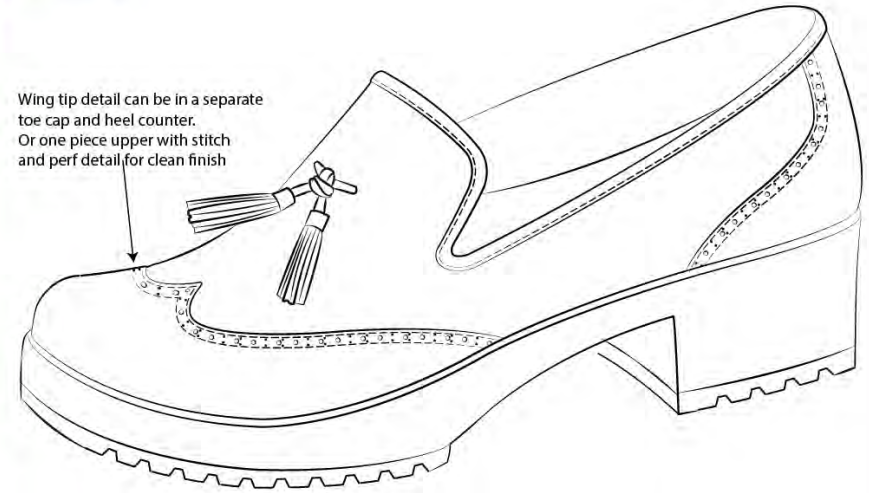

NORDSTROM



Oxford with Piping
Bottom as Andrea.



band of gypsies



Mariette



aaah...André



FUZZY



FURRY



Winter

andré assous



Hush Puppies®

RETAIL VALUE- CEMENT BOOTIE 5
UNIT OR WELTED BOTTOM WITH STACK HEEL
PULL-ON PERF SUEDE BOOT SHAFT FOLDS
DOWN AS COLLAR

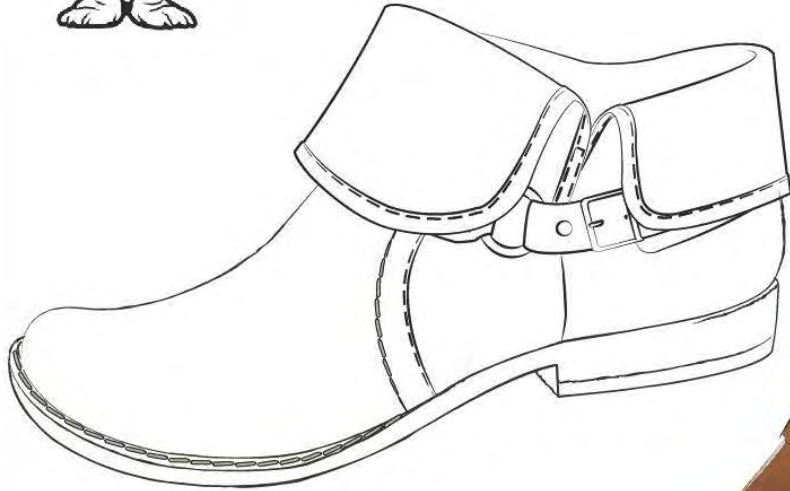

Loafers

& Friends

André Assous

aaah...André



CARYN



LE MANS



Driving
andré assous



ROCKPORT®



Hush Puppies®

RETAIL VALUE- CEMENT CONSTRUCTED LOAFER #1
PERF SUEDE OR KID SUEDE, PLUS METALLIC SKU'S





Hush Puppies®

CLEAN LUG- 2 GILLET
RETRO TO '90'S' LOOK WITH STYLIZED MODERN APPROACH TO LUGS.
UPPER IN COLORED SUEDE
BOTTOM CAN BE GUM OR BLK/DK BRN
NATURAL STITCH UPPER CAN ACCENT WITH GUM BOTTOM



Hush Puppies®

CLEAN LUG- 4 OXFORD BROGUE
RETRO TO '90'S' LOOK WITH STYLIZED MODERN APPROACH TO LUGS.
BOTTOM CAN BE GUM OR BLK/DK BRN



Hush Puppies



Hush Puppies®

CLEAN LUG- 1 MULE/CLOG
RETRO TO '90'S' LOOK WITH STYLIZED MODERN APPROACH TO LUGS.
UPPER IN SUEDE OR NUBUCK WITH LEATHER KEEP
(RAW EDGE ON KEEPER)

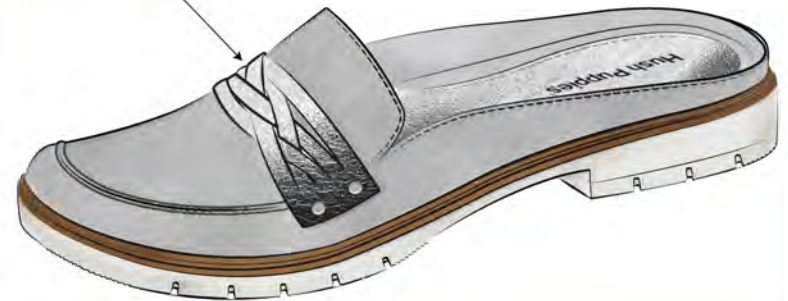

Hybrids

Ukies



NORDSTROM



earth.



KALSØ

SLIP ON #5- ASYMMETRIC SUPER SOFT GLOVE LINE CONSTRUCTION WITH ROLLED TOP-LINE AND SLIGHTLY PADDED COLLAR

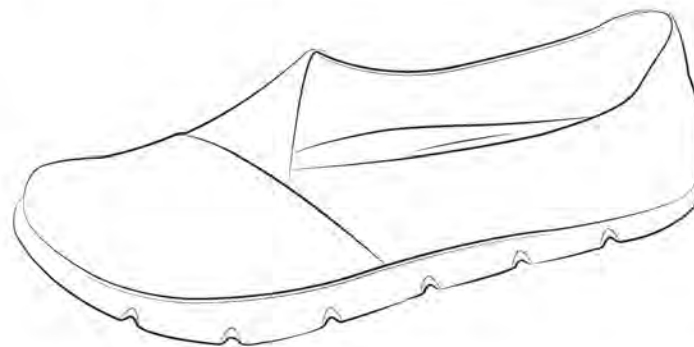

earth.

Hush Puppies



Hush Puppies

LOW CASUAL UNIT- #5- BALLERINA
-MATERIAL MIX UPPER
-METALLIC/NUBUCK
-PERF/SOLID



Dr.Scholl's

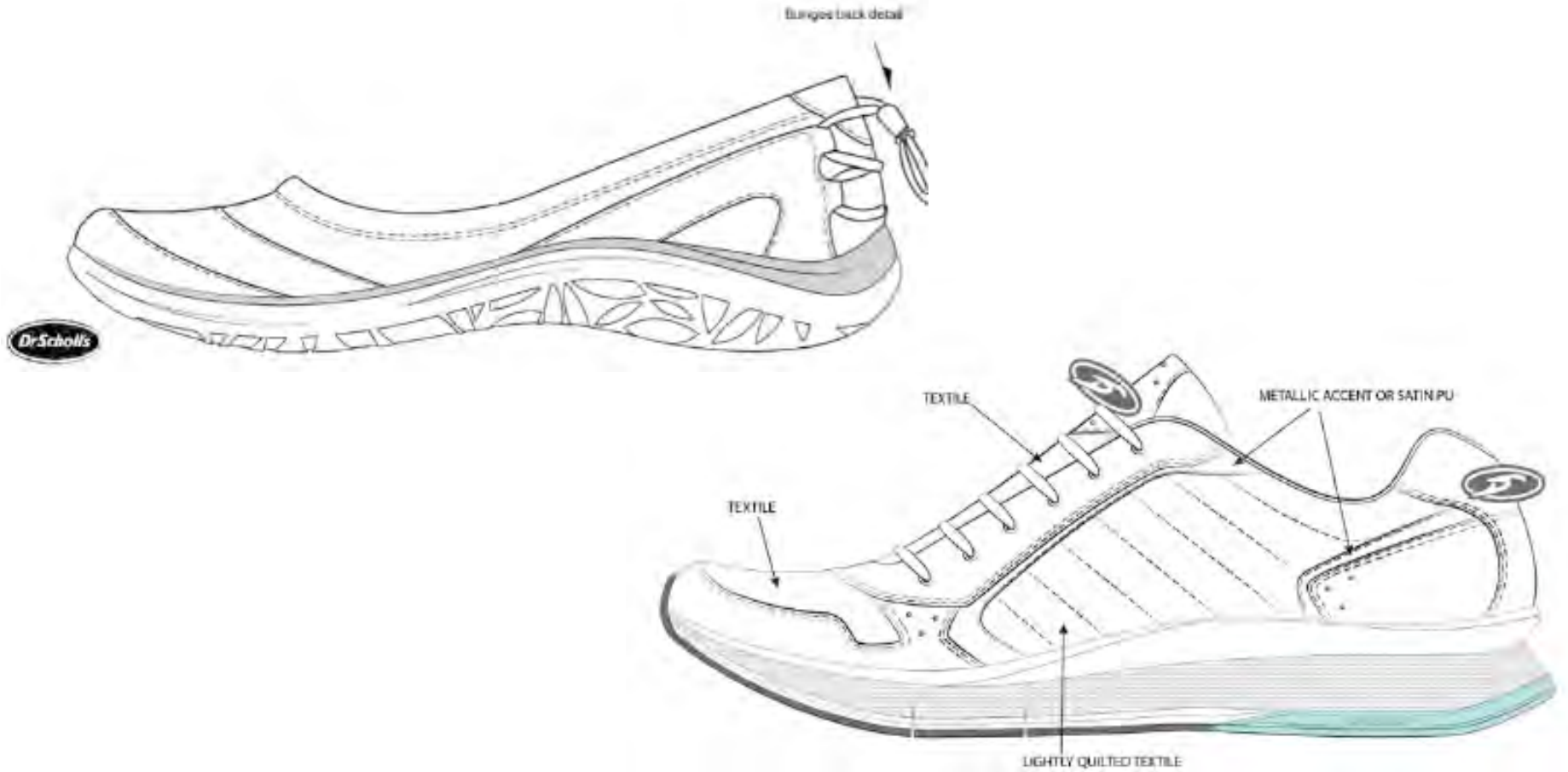

Dr.Scholl's

BEA UPDATE -UPPER 5 FRONT ZIPPER

COLORED NYLON ZIPPER
LACE MESH OR NOVELTY MESH

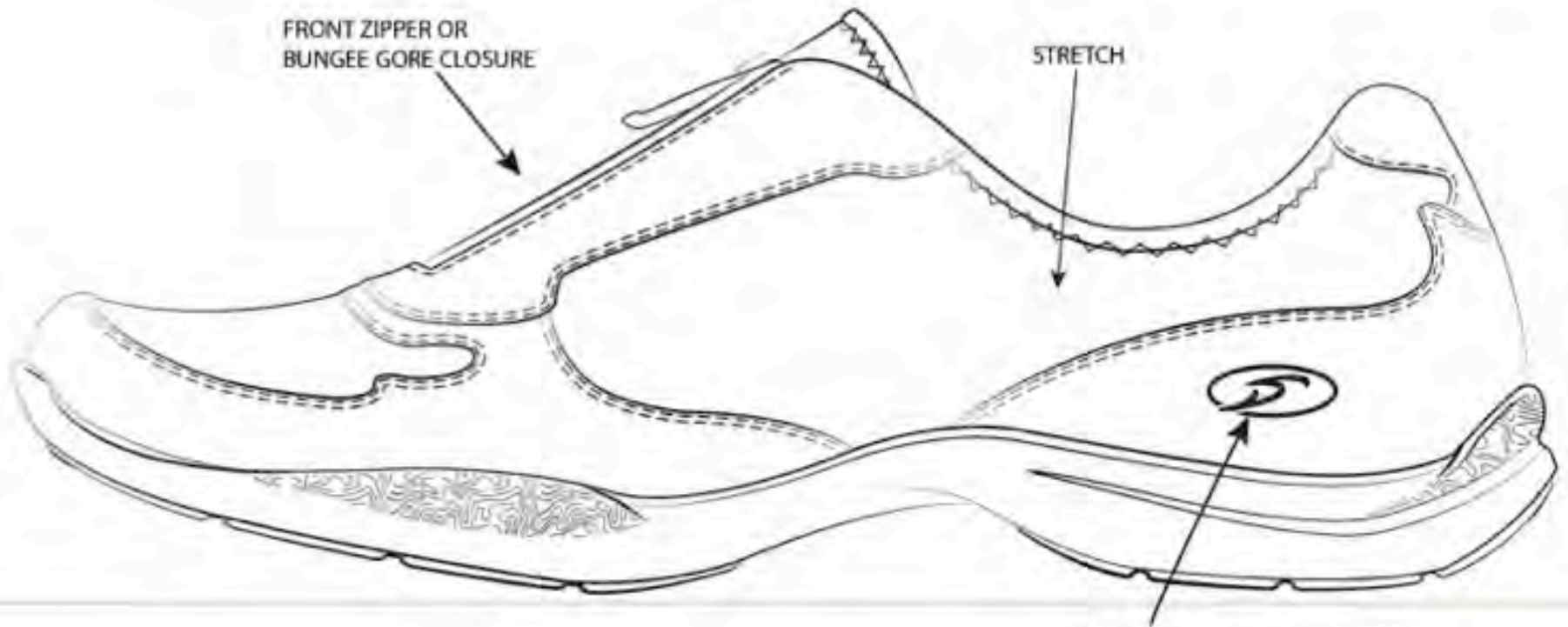

FRONT ZIPPER OR
BUNGEE GORE CLOSURE

STRETCH

HEAT EMOSS OR TRANSFER LOGO



Sneakers

Fall Winter 2018
Bella Center - CIFF



Stand C3-117 31.1 - 2.2. 09:00-18:00 www.mariette.no

Hår/Makeup: Marthine Egilsdatter Bøe Foto: Bjørnar Sveinsson

MARIETTE

Mariette



earth



Hush Puppies



Outdoor



KHOMBU



KHOMBU



Atsco Brands- Design consultant for 16 years in different categories and brands.

KHOMBU

Printed Jersey and Rubber



NEW FLING 2

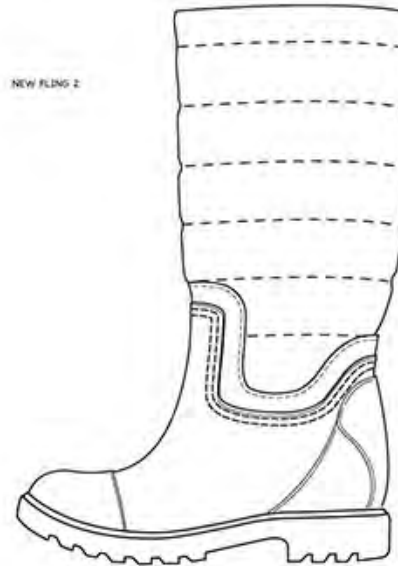

FLING 4



RUBBER BOOTS

FLING 3

- A. RUBBER FOOT
- B. BRUNISHED LEATHER OR PU SHAFT AND HARNESS

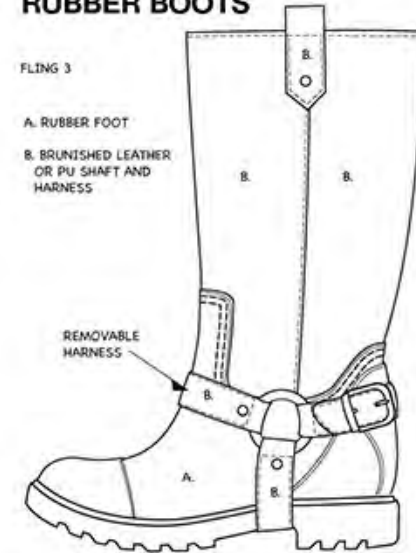

NEW FLING 5

- A. RUBBER
- B. SUEDE



Dress

Fashion

band of gypsies

LASER CUT SUEDE WITH SCORE LINE DETAILS

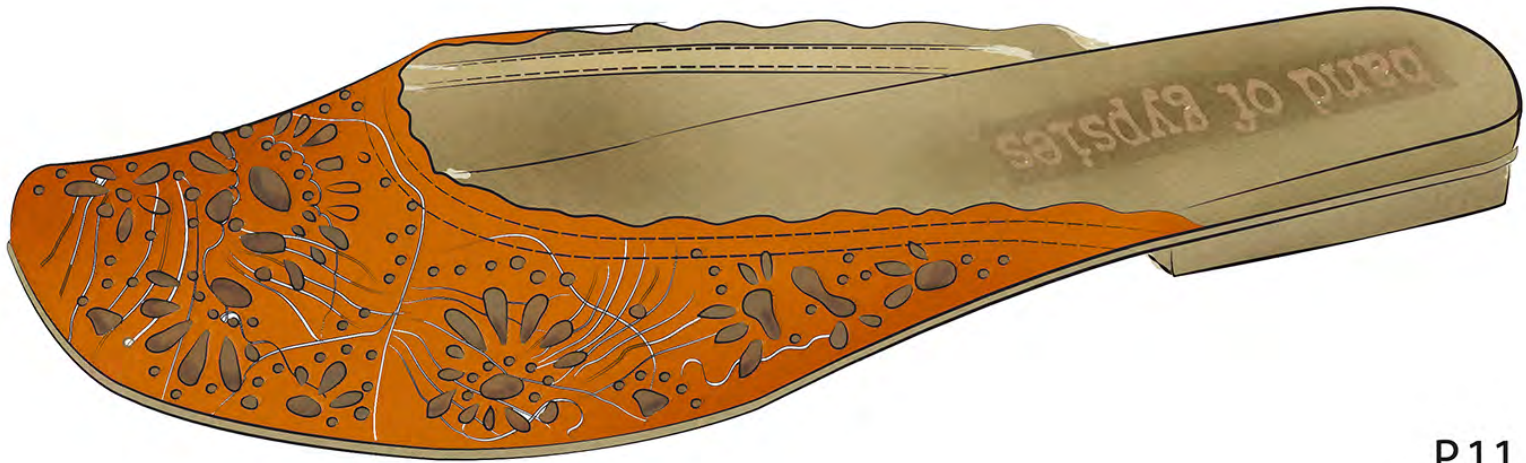

NORDSTROM



Ukies



Leather "Espadrille" 3-Upper with Tie
Small stud detail
2 Vamp options
Bottom as Paloma

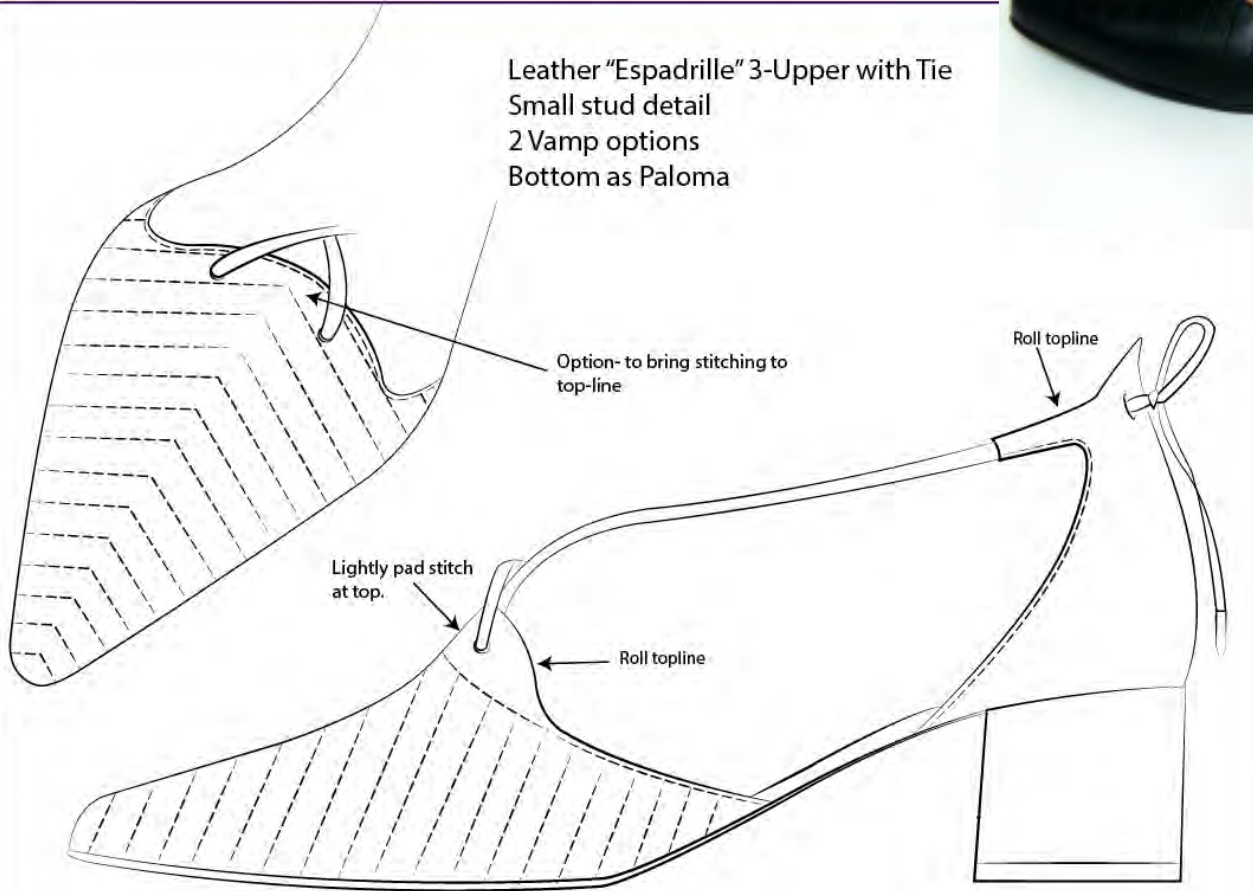

UPPER IS REVISED

Ukies

Laser Cut Tie Mary Jane
Created wrapped insole for open shank
Bottom as Paloma

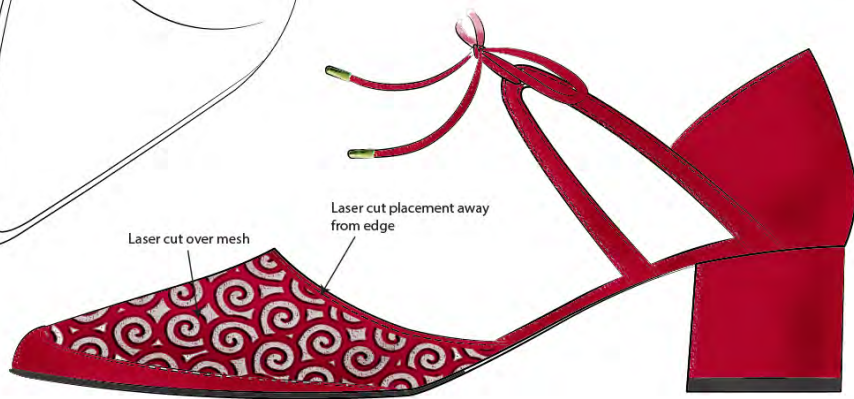

Laser cut over mesh

Laser cut placement away from edge

Bottom as Paloma

SMOKING OXFORD
NO LACE OXFORD SLIP ON
HIGH SHINE / NOT TOP STITCHING

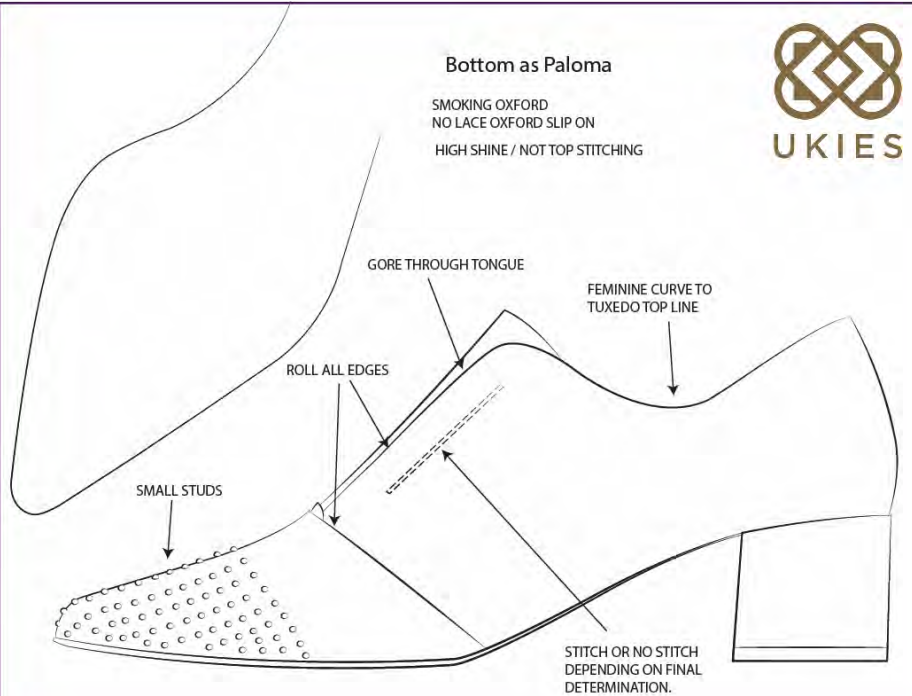

GORE THROUGH TONGUE

FEMININE CURVE TO
TUXEDO TOP LINE

ROLL ALL EDGES

SMALL STUDS

STITCH OR NO STITCH
DEPENDING ON FINAL
DETERMINATION.

FN

New York Transit
Pulls all Stops

Comfort Brands
Get Racy

Go Softly

For spring 2001, men's and women's designers are opting for the ease and versatility of latex and other materials, including jute, raffia and leech, with studded earth tones, resulting in comfortable footwear that melds fashion and function. Here, a jute-and-raffia espadrille from ANDRÉ ASSOUZ makes a quiet statement.

FN



 **andré assouz**
Featherweights

Medical

Comfort

PANDERE

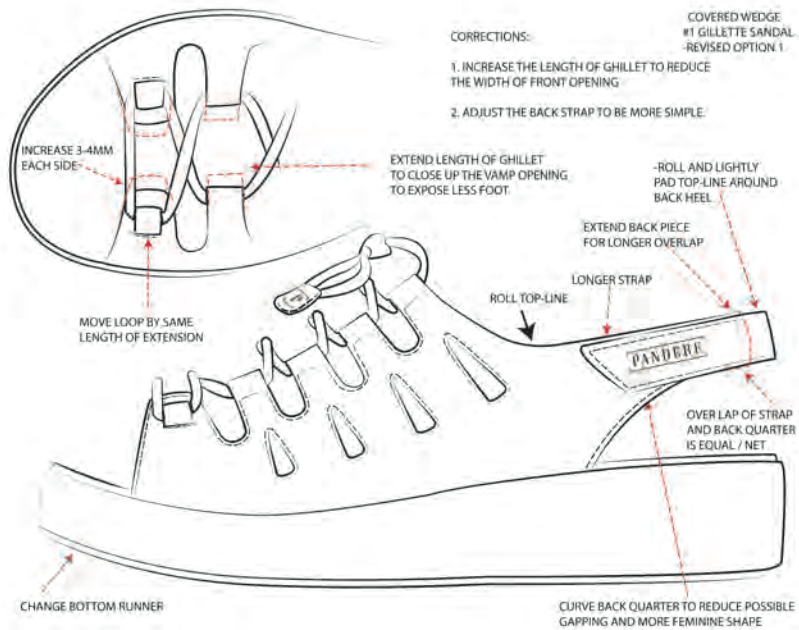

3D Expansion



3D Expansion

PANDERE 3D COMFORT

SPORT #2 -SNEAKER WITH BUNGEE BACK DETAIL- REVISED

- A. FLOATER
- B. STRETCH AIRMESH



PANDERE 3D COMFORT

COLOR 1

LIGHT GREY NUBUCK WITH WHITE BOTTOM



PANDERE

3D Expansion

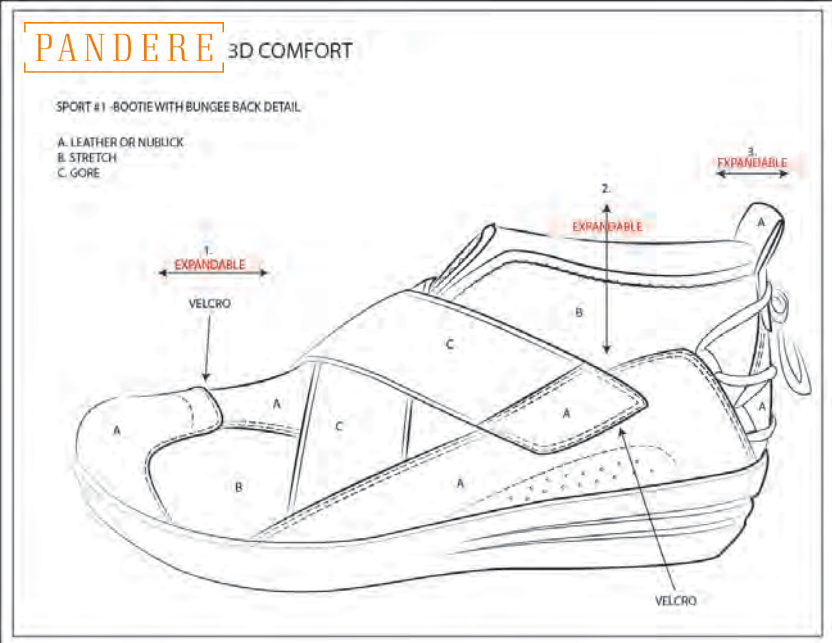

PANDERE

3D Expansion

FALL 2020 EXTRA WIDE LOW BOOT-#2

- NYLON LACE FRONT FOR ADJUST
- BUNGEE LOOPS FOR STRETCH AND EASE
- LOWER VERSION THE FIRST LOW BOOT
- SHEARLING TOP-LINE AROUND FRONT PIECE

UPPER A: SUEDE
UPPER B LYCRA

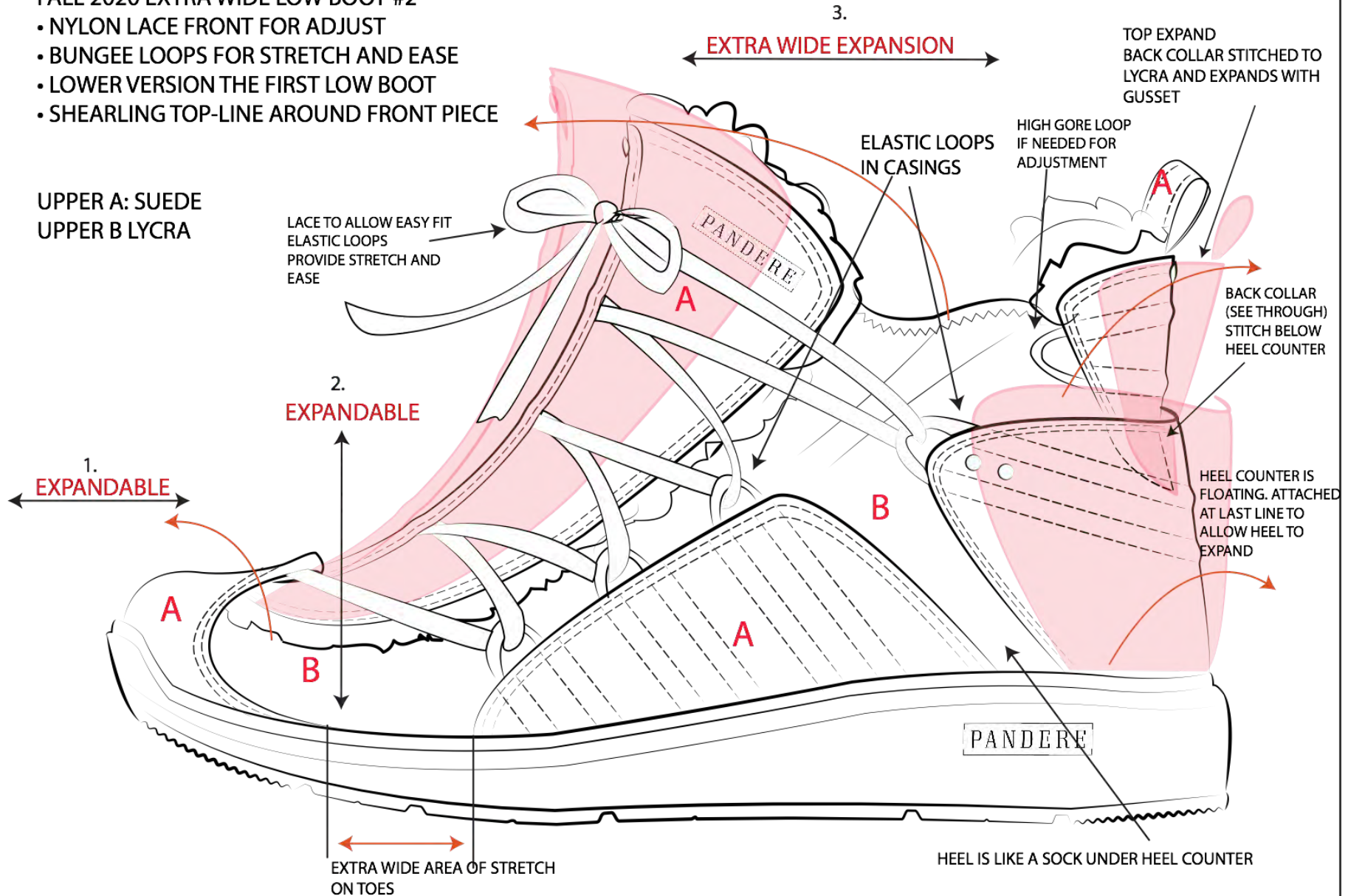

Technical Drawings

PLEASE ADJUST TO LAST- SOFT RADIUS EDGE ON ALL OF UNIT

LUG PATTERN IS DEEPEST PART ANGLE LUG OR BEVEL EDGES

FLOWER SHAPE IS MEDIUM DEEP CONCAVE EMBOSS AREA SATIN/SMOOTH FINISH

PIN LINES ARE LEAST DEEP

SMALL CIRCLES 1.5MM CONCAVE EMBOSS SATIN FINISH

LOGO PLUG

LIGHT SANDBLAST AT BOTTOM OF LUGS

EMBOSS SHAPE 1.0MM-SMOOTH/SATIN FINISH

LIGHT SANDBLAST TEXTURE THROUGH CONTOUR AND UP SIDE WALL-MATTE FINISH

2.0MM DEEP GROOVE SMOOTH/SATIN FINISH AT BOTTOM

MEDIUM SANDBLAST

SIDEWALL CONTOUR WITH ACTION GROOVE

2.5MM

1.0X1.0MM PIN LINE

TEXTURE IS LIGHT EMBOSS

SOFT MODELED CONTOUR ARCH

1.5 DEEP

BACK IS UP 12.0MM

2.5MM

SLIGHT WELT ON TOP-LINE IN SOME AREA CAN BE PAINTED OR SECOND COLOR

12.0MM

-LIGHT SQUIGGLE TEXTURE SLIGHTLY EMBOSSED FADES TO NOTHING AS IT ROUNDS SIDE OF UNIT

20.0MM

35.0MM

FADE TO 1.5MM

9.0MM

SMOOTH RADIUS

18.0MM

2.5MM

ARCH UP 12-14MM

FADE TO 1.0MM

2.5MM

FADE TO 1.0MM

24.0MM

WELT

2.5MM

2.5MM

2.0MM

FADE TO 1.0MM

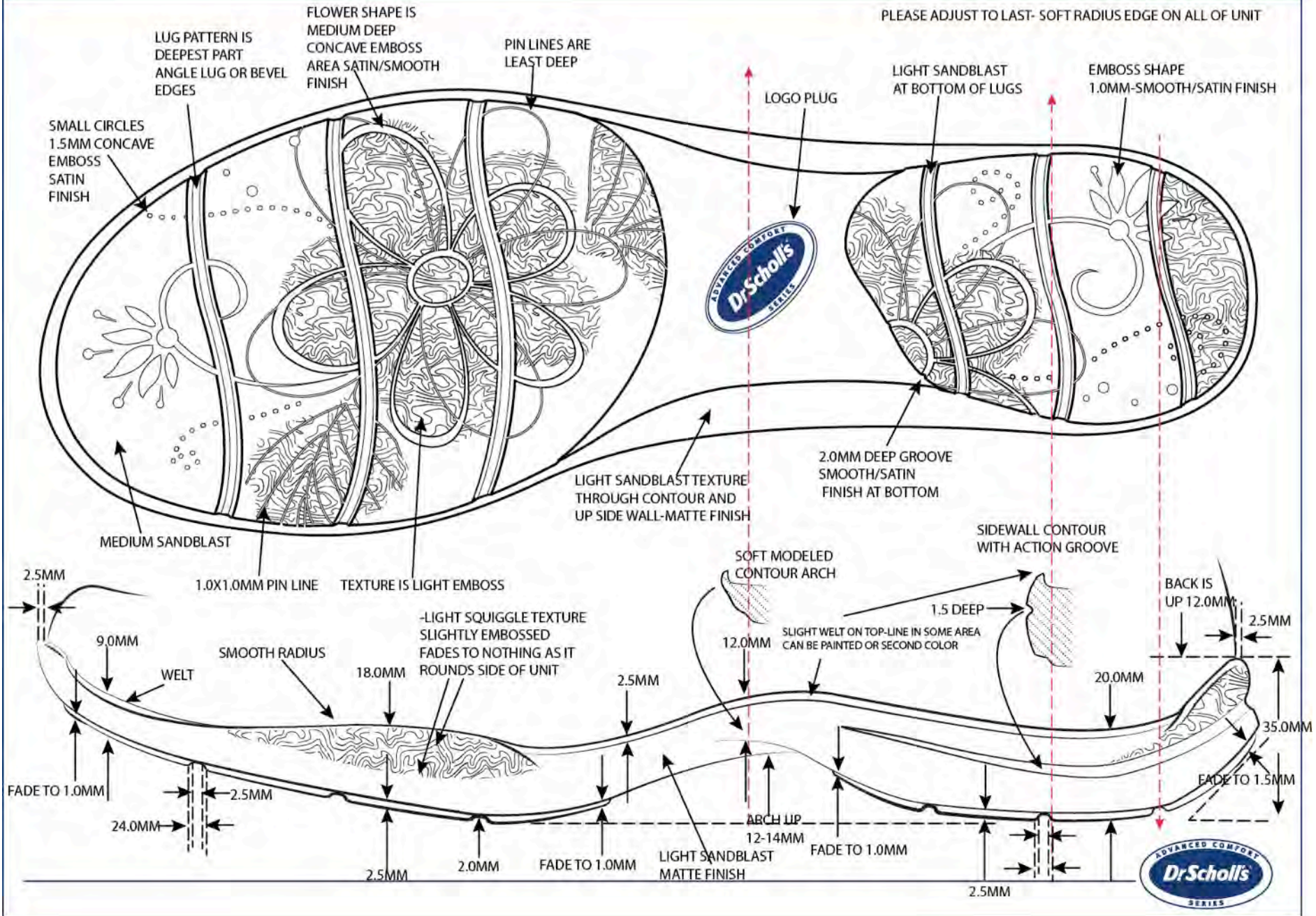

LAVISH BOTTOM DESIGN: PAISLEY FLORAL DESIGN

-LAST: LUXOR LAST AND FOOTBED.
SEE ADDITIONAL PAGE FOR SOCK PRINT OR EMBOSS DESIGN

-CONCEPT FOR PU OR TPU BOTTOM- TO BE DETERMINED

-INSIDE CORE PATTERN WILL BE DETERMINED BY FACTORY DEPENDING ON COMPOUND USED
*MUST BE AS LIGHT WEIGHT AS POSSIBLE

ANGLE LINES DRAWN TOE HEEL, TOE AND SIDE WALL FOR CONTOUR
SOFT RADIUS EDGES.

SATIN OR POLISHED MATTE FINISH (NOT SHINY)- TWO TONE OR BRUSHOFF IF POSSIBLE

SECTION A:A

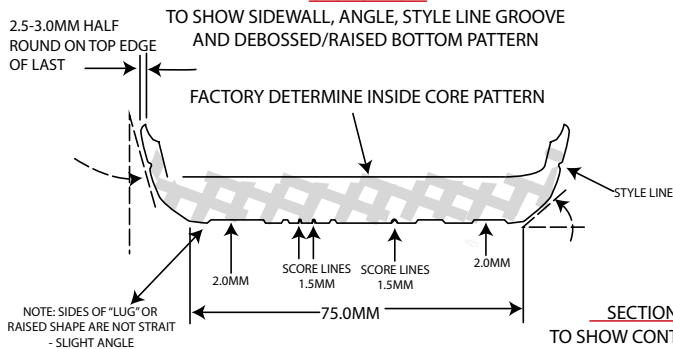

SECTION B:B

TO SHOW CONTOUR ARCH AND EMBOSS LOGO

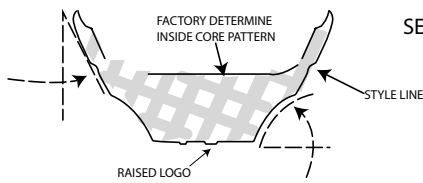

BACK HEEL

STYLE LINE FADES TO ZERO AT BACK

PHANTOM LINE TO SHOW ARCH

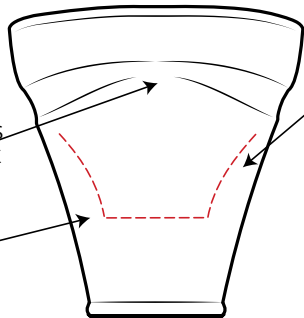

SECTION A:A

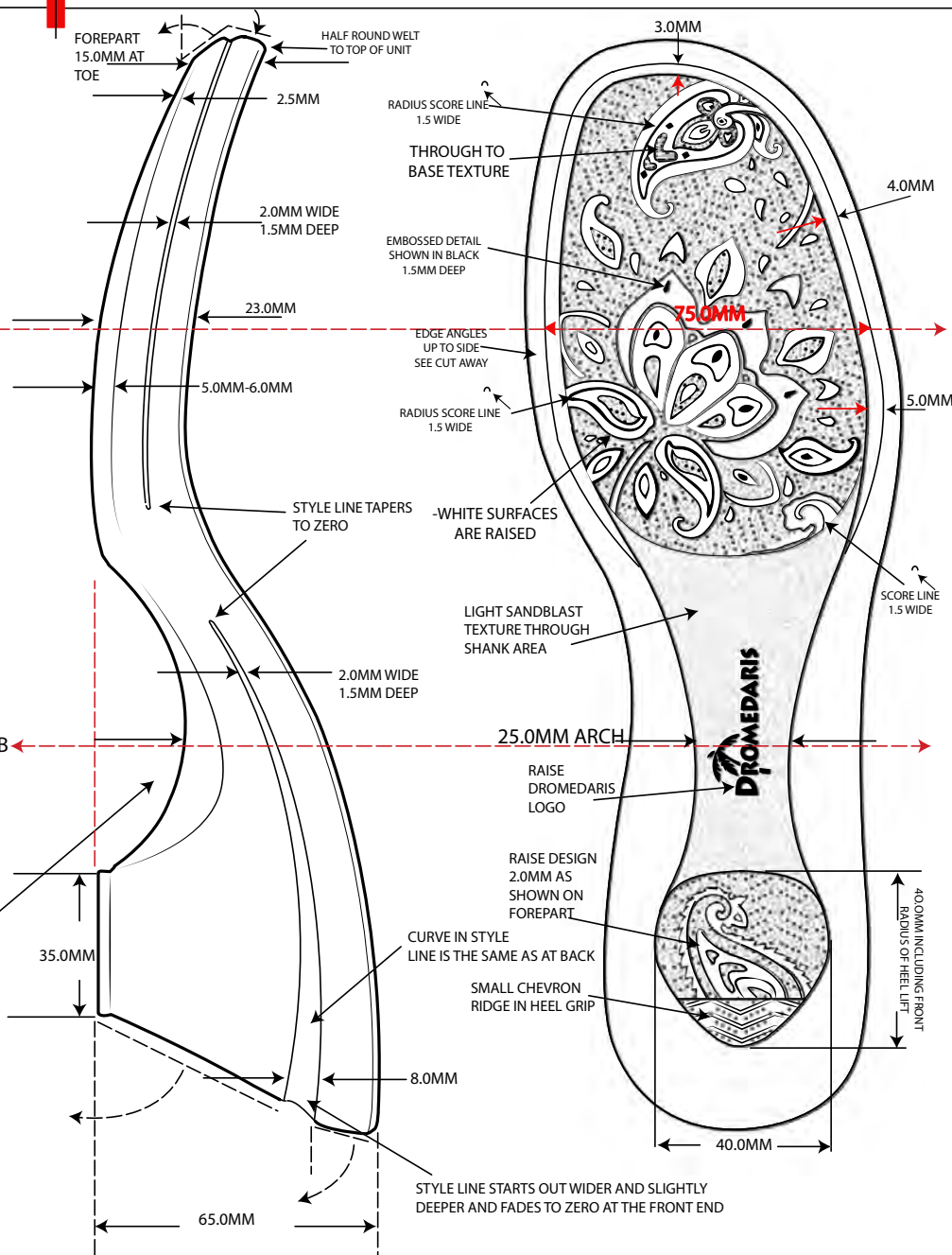

KHOMBU

TRIPD SHELL AND BOTTOM UNIT- ALL MEASUREMENTS ARE APPROXIMATE. NOT FROM A LAST BOTTOM INHER- ADJUST AS NEEDED.

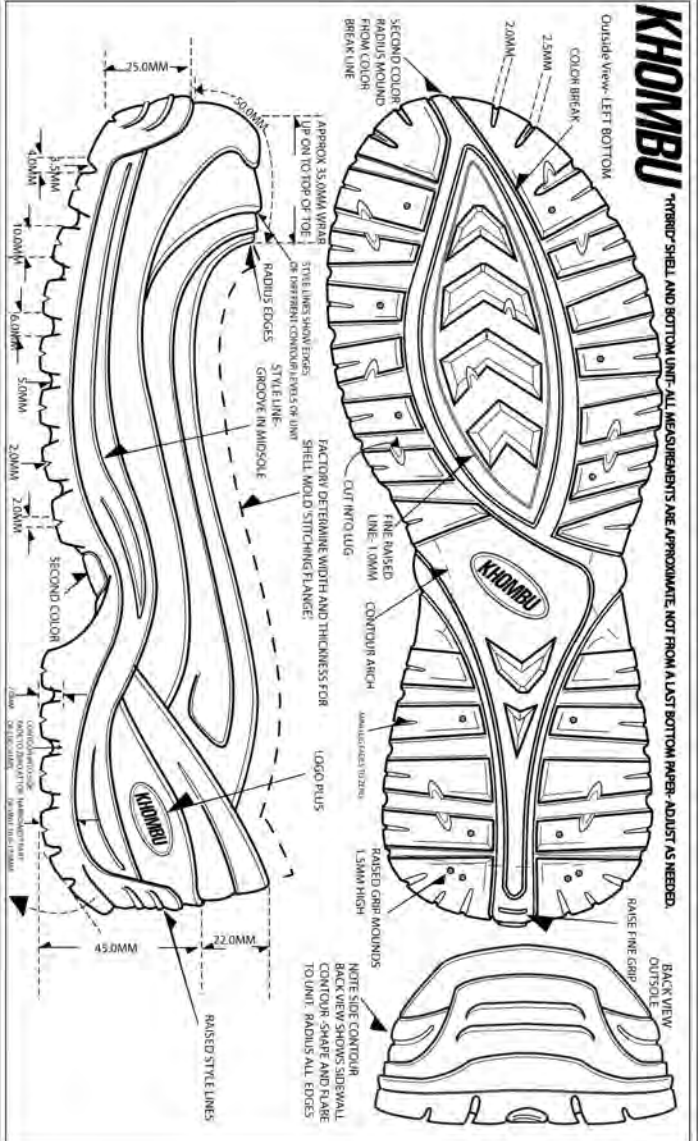

KHOMBU

Outside View- LEFT BOTTOM

